

Gama  
**PREMIUM**

**Calientaplatos**  
Pando plate warmer

**PCP-9600**

A+



Acceso / Access WEB

Rango de temperatura 30° a 80°	Operating temperature range 30°C to 80°C
Servicio para 6 personas	Service for 6 people
6 platos planos de 24 cm	6 x 24 cm flat plates
6 platos soperos de 10 cm	6 x 10 cm deep plates
1 fuente de 17, 19 o 32 cm	1 Baking bowl of 17Ø cm , 19Ø cm or 32Øcm
20 platos de 28cm de diámetro	20 flat plates of 28 Ø cm
80 tazas de café	80 coffee cups
40 tazas de té	40 tea cups
Base antideslizante	Non-slipping base
Apertura Push-to-open	Push-to-Open
Frontal de cristal negro	Black glass front
Touch Control	Touch control
Tiempo de 0 - 4 horas	Timer from 0 to 4 hours



**Sistema de aire caliente con termostato y ventilador que distribuye de forma óptima el calor en el cajón.**

El fondo del cajón está provisto de un recubrimiento antideslizante que impide que la vajilla se mueva al abrir o cerrar el cajón.

**Hot Air Fan and thermostat system for evenly heat fine distribution across the drawer.**

The bottom of the drawer is provided with a non-slip coating avoiding the dish from moving when opening and closing the plate warmer.

**Funciones especiales / Special functions**



Temperaturas / Temperatures*	
Precaentar vajillas Preheating crockery	60°
Calor constante Constant heat	70°
Desgongelar Defrost	30°
Calentar Heating	80°
Cocción a baja temperatura Low temperature cooking	80°

**Esquemas medidas / Technical Drawings**

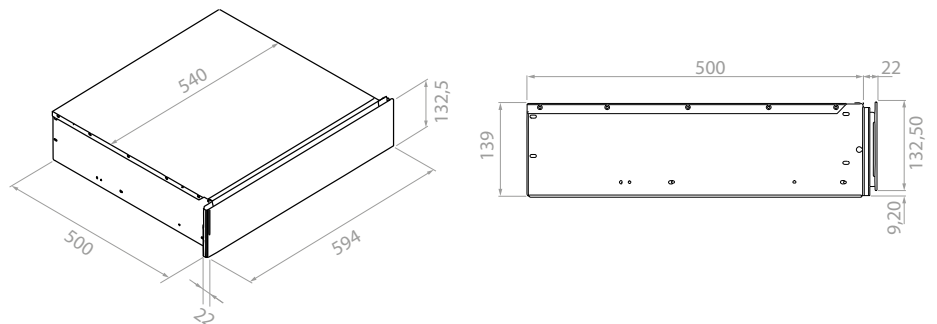

(\*) Los valores indicados son orientativos y pueden variar según las condiciones de uso, el material de la vajilla y la cantidad de carga.  
The values given are approximate and may vary according to the conditions of use, the material of the dishware and the amount of the amount of load.